

# TAGLIAVERDURE TAGLIAMOZZARELLA TVZ

TVZ-CA  
Coperchio ALLUMINIO

TVZ-CI  
Coperchio INOX



**I**

- Realizzazione in lega di alluminio e acciaio inox.
- Motore ventilato per uso continuo.
- Design estremamente compatto per una migliore gestione degli spazi in cucina.

- L'esclusivo sistema a caduta diretta del prodotto permette di lavorare anche prodotti morbidi e delicati come mozzarella e altri formaggi.
- Sicurezza garantita da 3 microinterruttori: su leva, coperchio e vasca.
- Vasca raccogli-fette con interblocco in dotazione.
- Disponibile con coperchio inox lavabile in lavastoviglie.
- Ampia disponibilità di dischi per tutte le applicazioni.

## DISCHI FETTE



A1-A2-A3



A4-A8-A10



A14



A5  
PER POMODORINI

## DISCHI BASTONCINI

## DISCHI CUBETTI



B4-B6-B8-B10



C5



C8-C10



C14-C20

## DISCHI PER GRATTUGGIARE

## DISCHI PER SFILACCHIARE



G1-G2



G8



S3-S4-S7-S9

**EN**

- Aluminium alloy and S/S construction.
- Ventilated motor for continuous operation.
- Thanks to its compact design the machine is easy to install inside every kitchen.

- The exclusive feeding system makes easy to process also soft products like mozzarella cheese.
- Safe operation is ensured by interlock switches on product pusher, lid and collecting tray.
- Version with dishwashing safe S/S lid available.
- Large number of discs available for every purpose.

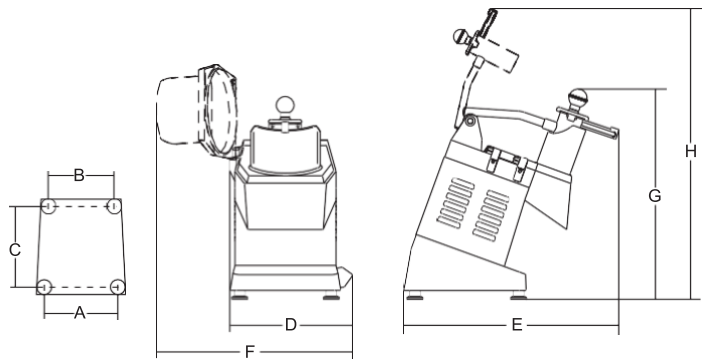

Potenza  
Power  
Spannung  
Puissance

Alimentazione  
Power source  
Betriebspannung  
Alimentation

Giri disco  
Disc revolutions  
Kreislaf  
Tours Disques

Peso netto  
Net weight  
Nettogewicht  
Poids net

Dimensioni imballo  
Shipping  
Verpack. abmessungen  
Dim. emballage

Peso lordo  
Gross weight  
Bruttogewicht  
Poids brut

	watt/HP	230-400V/50Hz	r.p.m.	mm	mm	mm	mm	mm	mm	mm	mm	kg	mm	kg
TVZ-CI	515 /0,7	230-400V/50Hz	300	225	195	255	280	510	-	510	770	17,5	720x350x500	21
TVZ-CA	515 /0,7	230-400V/50Hz	300	225	195	255	280	510	400	510	770	18,5	720x350x500	22